

1

2

3

4

A

B

C

D

E

F

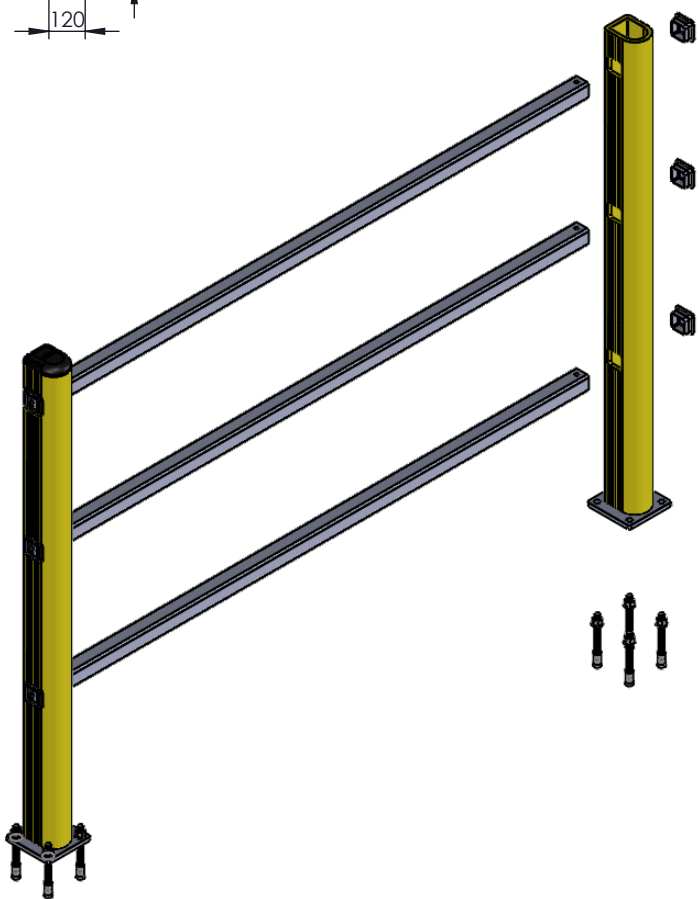
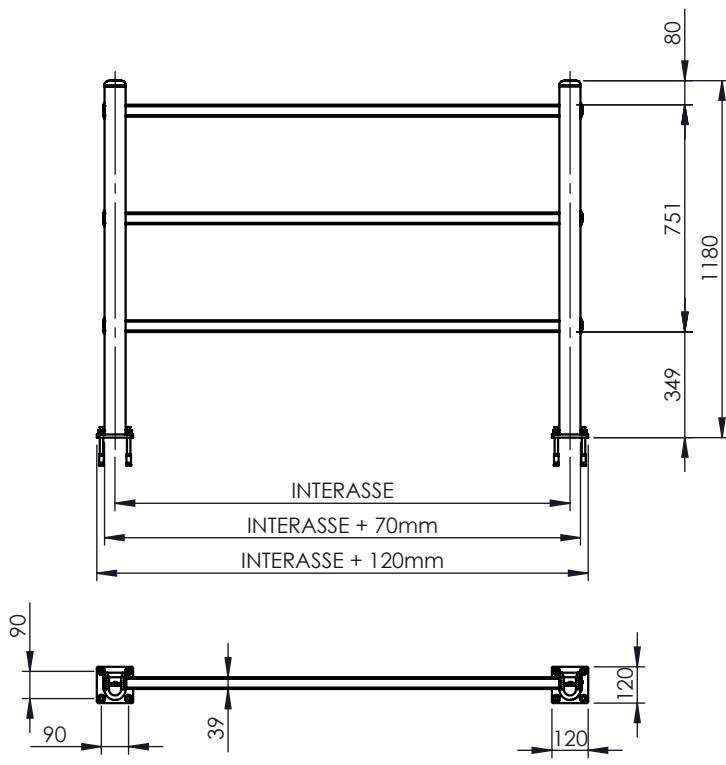

IMPACT RESISTANCE: 3300 J

Rif. UNI EN 22768/1

Classe di tolleranza	Desig.	Denominazione.	Scostamenti limite per dimensioni lineari *							
			0,5° ±3	>3 ±6	>6 ±30	>30 ±120	>120 ±400	>400 ±1000	>1000 ±2000	>2000 ±4000
f		fine	±0.05	±0.05	±0.1	±0.15	±0.2	±0.3	±0.5	
m		media	±0.1	±0.1	±0.2	±0.3	±0.5	±0.8	±1.2	±2
o		grossolana	±0.2	±0.3	±0.5	±0.8	±1.2	±2	±3	±4
v		molto grossolana	±0.5	±1	±1.5	±2.5	±4	±6	±8	

excludes bevels edge
* Per dimens. < di 0.5 mm, lo scostamento si indica dopo la dimens.

Rev. n°. 00 Data 25/01/16 Modifica: Prima emissione Firma Fabio M.



Materiale PVC
Scala 1:1
Denominazione HAND RAIL ESP

Q.tà _____
Nr. Disegno _____

1° Controllo _____
2° Controllo _____